



General

Get all the details of the scene with the Quaddrix® viewQ QTX-61 Mini Dome Series. The best combination of an easy to install mini dome camera and powerful 690 HTVL Effective resolution image sensor. With the varifocal lens 2.8-10mm you will be able to meet all of your surveillance requirements.

Parts Included

- QTX-61 Minidome

Parts To Be Ordered Separately

Order Information	Part Number	Description
Power Supply	QT-12DC-800mA	Power Supply 12VDC 800mA

Technical Drawing

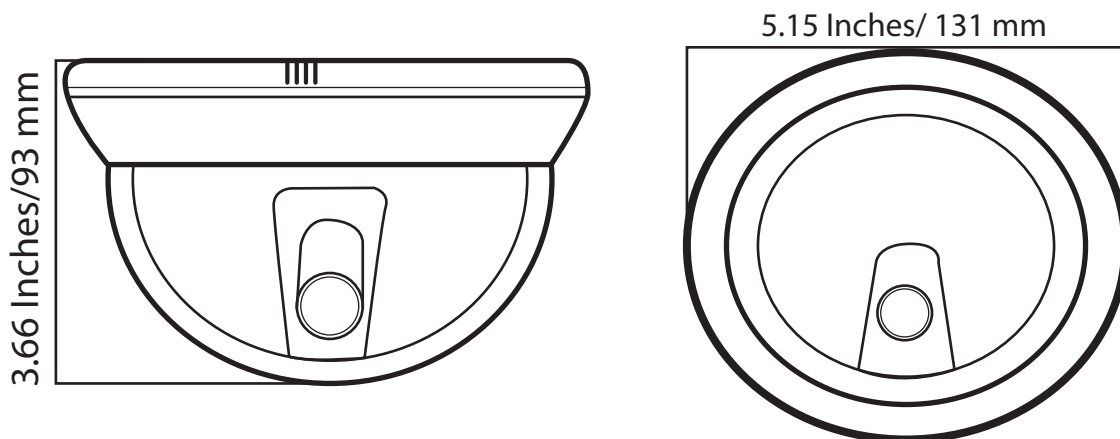

Technical Specifications

Optical Specifications

QTX-61-J3	
Imaging	
Horizontal Resolution	690 HTVL Equivalent
Vertical Resolution	460 VTVL
Dynamic Range	120dB max (102db Typical)
Sensitivity	0.1 Lux min illumination f1.2, 50 IRE, 30 FPS, 2850K, Color)
Digital Slow Shutter	2x/ 4x/ 8x/ 16x/ 32x
Noise Reduction	3D Motion Adaptive Noise Reduction (3DNR)
SNR	> 50 dB MAX
AGC	Programmable up to 50 dB
Auto Iris	DC,
Back Light Compensation	BLC On/Off
Day/Night	True Day, Night
White Balance	ATW, PTWB
WB Range	2000 - 11,000K
Meterig Zones	4, User Definable
Video	
Video Standards	NTSC/PAL (software selectable)
Aspect Ratio	4:3 - 16:9 Scaled
Synchronization	Internal or Line Lock
Flicker Reduction	On/Off
Image Flip	Horizontal and Vertical
Image Freeze	Yes
Digital PTZ	Pan, Tilt, Zoom (1x - 8x)

QTX-61-J3	
Interfaces	
Identifiers	Camera ID / Camera Number
Local Control	OSD control interface in camera cable
Visual	On-screen Display
Privacy Zones	12 Programmable Zones
Activity Zones	4 Programmable Zones
Sensor	
Type	Digital Pixel System ©
Capture	Global Electronic Shutter
Electronic Shutter Speed	1/25 - 1/30 720 second(f.1/2)
Optical Format	1/3" (6.3mm Image Diagonal)
Total Pixels	768 x 548 (420, 864)
Effective Pixels	758x540(409,320)
Pixel Size	7um x 7um
Color Filter Array	CMY+OLPF and IR Cut Filter
Power Supply	
Voltage	12 DVC +/- 10%
Power	
Enviromental	
Temperature	-10 to 50 Degrees C (operating)

Other Specifications

QTX-61-J3	
Lens	
Lens Type	Vari Focal
Focal Length	2.8~10mm
Angle of View	20°~65°(V) / 27°~81° (H)
Mount Type	Board
Iris Control	Auto Iris DC
TDN (True Day Night)	Yes. Mechanical Filter
Power	
Voltage	12VDC

Functions

- **viewQ's Digital Pixel System Technology** delivers high-resolution, crystal clear images that accurately capture every aspect of any scene.
- **Ultra-wide dynamic Range** imaging accurately captures all of the critical details in a scene including highlights, shadows, and everything in between without compromising image quality or color accuracy
- **Effective Resolution Is Usable Resolution:** Increased vertical resolution increases a camera's effective image resolution. Higher VTVL allows CCTV cameras to capture more usable detail in an image. At the same time it prevents the camera from capturing false color noise that obscures details in images, unnecessarily bloats DVR file sizes, and confuses analytics algorithms. Standard DVRs as well as standard. CRT and LCD video monitors support the additional vertical resolution. Effective resolution, as its name implies, is the best indicator for video security professionals of how effective a CCTV camera is really going to be in terms of capturing detail in an image.
- Enhanced low-light performance makes **viewQ** the natural choice for both indoor and outdoor cameras for all lighting conditions.
- **DNR (Digital Noise Reduction):** The Digital Noise Reduction technology (DNR) improves Image quality by reducing fixed and random noises; as an additional benefit, DNR will help to optimize the recording process.