



**General**

Magna Line and its line of Infrared Bullets offer various options for high quality indoors/ outdoors applications. With the QT-800 series, you can choose between different resolution options, infrared scopes ranging from 15m up to 50m, and a variety of lenses that will ensure the best picture even in total darkness in a different kind of solution.

**Parts Included**

- QTX-800 Bullet / Wall Bracket

**Parts To Be Ordered Separately**

Order Information	Part Number	Description
Power Supply	QT-12DC-1.25A	Power Supply 12VDC 1200mA

**Technical Drawing**

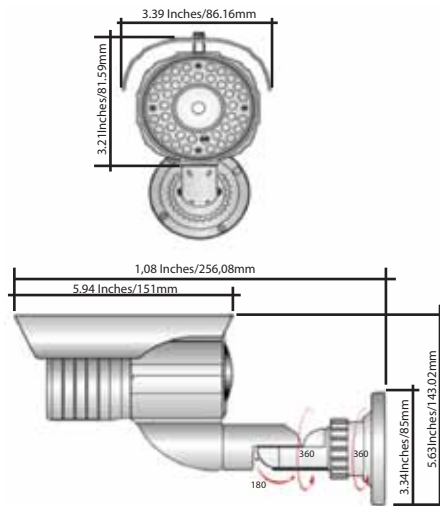

## Technical Specifications

## Optical Specifications

QTX-800-J11		QTX-800-J12	
Imaging			
Horizontal Resolution	690 HTVL Equivalent		
Vertical Resolution	460 VTVL		
Dynamic Range	120dB max (102db Typical)		
Sensitivity	0.1 Lux min illumination f1.2, 50 IRE, 30 FPS, 2850K, Color)		
Digital Slow Shutter	2x/ 4x/ 8x/ 16x/ 32x		
Noise Reduction	3D Motion Adaptive Noise Reduction (3DNR)		
SNR	> 50 dB MAX		
AGC	Programmable up to 50 dB		
Auto Iris	DC		
Back Light Compensation	BLC On/Off		
Day/Night	True Day, Night		
White Balance	ATW, PTWB		
WB Range	2000 - 11,000K		
Meterig Zones	4, User Definable		
Video			
Video Standards	NTSC/PAL (software selectable)		
Aspect Ratio	4:3 - 16:9 Scaled		
Synchronization	Internal or Line Lock		
Flicker Reduction	On/Off		
Image Flip	Horizontal and Vertical		
Image Freeze	Yes		
Digital PTZ	Pan, Tilt, Zoom (1x - 8x)		

QTX-800-J11		QTX-800-J12	
Interfaces			
Identifiers	Camera ID / Camera Number		
Local Control	GPIO (Button/Joystick/DIP)		
Visual	On-screen Display		
Privacy Zones	12 Programmable Zones		
Activity Zones	4 Programmable Zones		
Sensor			
Type	Digital Pixel System ©		
Capture	Global Electronic Shutter		
Electronic Shutter Speed	1/25 - 1/30 720 second(f.1/2)		
Optical Format	1/3" (6.3mm Image Diagonal)		
Total Pixels	768 x 548 (420, 864)		
Effective Pixels	758x540(409,320)		
Pixel Size	7um x 7um		
Color Filter Array	CMY+OLPF and IR Cut Filter		
Power Supply			
Voltage	12 DVC +/- 10%		
Power			
Enviromental			
Temperature	-10 to 50 Degrees C (operating)		

## Other Specifications

QTX-800-J11		QTX-800-J12	
Lens			
Lens Type	Vari Focal		
Focal Length	2.8~10mm	9~22mm	
Angle of View	20°~65°(V) / 27°~81° (H)	9°~23°(V) / 12°~30°(H)	
Mount Type	Board		
Iris Control	Auto Iris DC		
TDN (True Day Night)	Yes. Mechanical Filter		
IR Illumination			
Infrared Wavelength	850nm		
Infrared Distance	15~30mt		
Power			
Voltage	12VDC		

## Functions

- **viewQ's Digital Pixel System Technology** delivers high-resolution, crystal clear images that accurately capture every aspect of any scene.
- **Ultra-wide dynamic Range** imaging accurately captures all of the critical details in a scene including highlights, shadows, and everything in between without compromising image quality or color accuracy
- **Effective Resolution Is Usable Resolution:** Increased vertical resolution increases a camera's effective image resolution. Higher VTVL allows CCTV cameras to capture more usable detail in an image. At the same time it prevents the camera from capturing false color noise that obscures details in images, unnecessarily bloats DVR file sizes, and confuses analytics algorithms. Standard DVRs as well as standard, CRT and LCD video monitors support the additional vertical resolution. Effective resolution, as its name implies, is the best indicator for video security professionals of how effective a CCTV camera is really going to be in terms of capturing detail in an image.
- Enhanced low-light performance makes **viewQ** the natural choice for both indoor and outdoor cameras for all lighting conditions.
- **IR Option:** The Infrared lighting option included in the QTX-800 series will operate in supervised areas between 15 and 50mts with low and zero visibility, thereby improving the performance of your CCTV solution.
- **DNR (Digital Noise Reduction):** The Digital Noise Reduction technology (DNR) improves image quality by reducing fixed and random noises; as an additional benefit, DNR helps optimize the recording process.
- **Weatherproof IP66 Rated,** created to withstand the toughest weather conditions and can be used in bright sunlight or rain.